



Full-air
Ford Transit 363
(2014 to present)



▶ **Product Information**

The Drive-Rite Rear Axle Full Air Suspension Kit incorporates our very own IntelliRide suspension control system. IntelliRide is a fully automatic, Electronically Controlled Air Suspension (ECAS) System. When fitted the system provides comfort while maintaining a programmed ride height irrespective of the load. Multiple vehicle heights are available at the push of a button. The IntelliRide system has automatic load levelling at each height.

The IntelliRide system continuously monitors inputs and component performance as a means of increasing safety and durability. The system recognizes and responds accordingly to potholes, cross-articulation and extended turns. This intelligence prevents unnecessary activity and air consumption. The system even recognizes unachievable heights, assisting in the prevention of possible damage above or below the vehicle.

Benefits of Drive-Rite Air Suspension:

- + Increased comfort and enhanced driving experience
- + Vehicle stability safely improved under all loaded conditions
- + Vehicle less sensitive to high cross winds resulting in reduced sway and improved handling
- + Individual adjustment of the air spring pressure allows side to side height adjustment
- + Optimized geometry (drive line angles)
- + Constant ride height – load independent
- + High-quality components manufactured in Germany, USA and Ireland
- + Easy to install and user friendly systems
- + Air Springs made by Firestone, the world's No 1 Air Spring Supplier
- + Reliable: Drive-Rite has more than 25 years of experience in air suspension business
- + Fully tested, approved and homologated by the Original Equipment Manufacturer and TUV





Full-air

Ford Transit 363
(2014 to present)

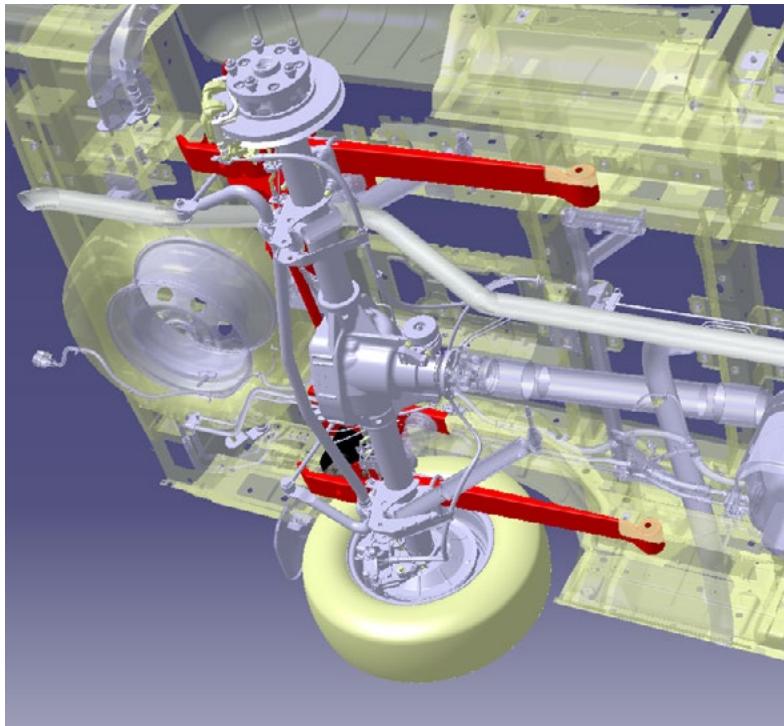

Handheld Controller
The Drive-Rite 2 Corner Handheld

▶ Technical Specifications

Model	Ford Transit 363
Year	from 2014 to present day
Kit Number	• DR.05.013370
Air spring Style	Firestone, Sleeve Air Spring
Kit Weight	+80 kg
Control System	IntelliRide, a user friendly Automatic height control system.
Compressor	AMK 12 V, max. 12 bar

Please check our website for further information and latest details on this application.

