

Complete suspension solutions for what you drive

DRIVE  RITE
AIR SUSPENSION SYSTEMS





DRIVE RITE

AIR SUSPENSION SYSTEMS

With over 20 years of experience in the automotive industry, Drive-Rite has developed into a leading supplier of air suspension solutions. Drive-Rite tailor make suspension systems to suit a wide range of vehicle applications from passenger car to commercial vehicle. Drive-Rite serve all market segments from the world's largest automotive companies, truck and bus manufacturers to specialised suspension builders.



Motorhomes

Drive-Rite suspension kits when fitted on motorhomes provide improved comfort and vehicle stability, while keeping the vehicle level under all load conditions. Drive-Rite design kits to assist vehicles with large overhang and limited ground clearance. On full air 4-corner applications the Drive-Rite IntelliRide system provides a unique auto levelling system commonly known as **Horizon Levelling**.



Ambulances

Drive-Rite provide easy to fit solutions for ambulance and patient transport offering the highest levels of suspension comfort and ride quality. The lowering facility provides easy access for patient transfer.



Wheel chair accessible

The Drive-Rite system allows lowering of the vehicle to its bump stops (lowest position) thus providing safe wheelchair access with a minimum angle of inclination. When driving the patient / driver benefit from increased comfort of riding the vehicle on soft progressive air springs.



Bus/Coach

When fitted on bus and coach applications the Drive-Rite systems offer improved comfort to the driver and passengers. The system is very flexible and can be configured to allow easy access with side to side and/or front to rear kneeling. Speed sensitive lowering of the vehicle height is possible when using the IntelliRide system for motorway use.



Transport

The Drive-Rite suspension systems adjust and adapt to changing load conditions. By varying the air pressure in the system we can provide many solutions for the transport of goods from delicate to heavy loads e.g. computer transport, car transporters, refrigerated and hi-cube vans, etc. Over-load detection is available on certain applications.



Off-Road, Pick-Up, SUV & 4x4

Drive-Rite provide a full range of suspension kits suitable for the off-road, SUV and pick-up market. The increased popularity of these vehicles in many applications has led to the demand for an adjustable air suspension to cater for the various loading conditions that these vehicles operate under. Typical applications range from high centre of gravity demountable campers, goods transport, 5th wheel and towing applications.





Product Range

Drive-Rite supply optimized designed suspensions tailored to your specific needs, yielding robust, reliable and durable products to assure unsurpassed performance.

Drive-Rite provide complete solutions from simple coil springs, semi-air (air assist) suspension to full-air suspensions and electronic control systems capable of interacting safely with the original vehicle.

Drive-Rite work closely with the original equipment vehicle manufacturers (OEM) to provide improved, comfortable, easy to install and user friendly systems. As a result Drive-Rite has received OEM approval and homologation from all the major manufacturers along with TÜV certification.

Working with accredited suppliers Drive-Rite provide a complete array of technological capabilities yielding a world-class product.



Semi Air Suspension

Drive-Rite air helper springs can be installed on most light commercial vehicles, motorhomes, vans and SUVs. Systems available for both leaf and coil spring applications. The double convoluted and tapered sleeve air springs offer comfort, maximum load support as well as years of worry-free service under any load condition.

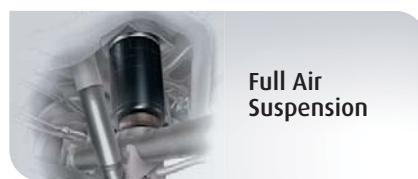

Full Air Suspension

Drive-Rite have developed a wide range of Full-Air Suspension Systems for many vehicle applications. Drive-Rite's suspension systems offer a smooth comfortable ride, lowering facility, multiple ride heights, are easy to install, user friendly and require little or no maintenance.



Project Suspension

Working with world class suppliers, having its own in-house suspension design team, the ability to develop special customer software and hardware allows Drive-Rite to provide tailor made solutions for specific customer needs. As such, Drive-Rite supplies numerous partners throughout the world.



Control Systems

Keeping your vehicle level and handling correctly is simple with Drive-Rite's air accessory program. These kits are designed to work with any semi-air system providing an on-board source of air. It's easy to maintain the ride you want regardless of the load or road conditions.



Intelliride

The highly versatile IntelliRide™ control system allows Drive-Rite to respond quickly to customer's suspension control needs. Having its own in-house software development and programming capabilities this allows Drive-Rite to work on network protocols, PC diagnostic tools and designing user interfaces.



Suspension Components

Drive-Rite can provide dependable performance air suspension products ranging from Air Springs, Air Compressors, Shock Absorbers, Coil Springs, Air Reservoirs, Height Sensors, Control Panels and Valves.

Electronic Control Systems



IntelliRide is a fully automatic, Electronically Controlled Air Suspension (ECAS) System. When fitted the system provides comfort while maintaining a programmed ride height irrespective of the load. Multiple vehicle heights are available at the push of a button. The IntelliRide system has automatic load levelling at each height.

The IntelliRide system continuously monitors inputs and component performance as a means of increasing safety and durability. The system recognizes and responds accordingly to potholes, cross-articulation and extended turns. This intelligence prevents unnecessary activity and air consumption. The system even recognizes unachievable heights, assisting in the prevention of possible damage above or below the vehicle.

- 1 Variable ride height – for access, off-road and high-speed driving
- 2 Load-levelling
- 3 Near-constant ride frequency – load independent
- 4 Variable spring rate with optional driver adjustment
- 5 Optimized geometry (Drive line angles)
- 6 Improved ride quality
- 7 Horizon (Auto) Levelling
- 8 Load sensing and over-load detection available
- 9 Improved head lamp aim

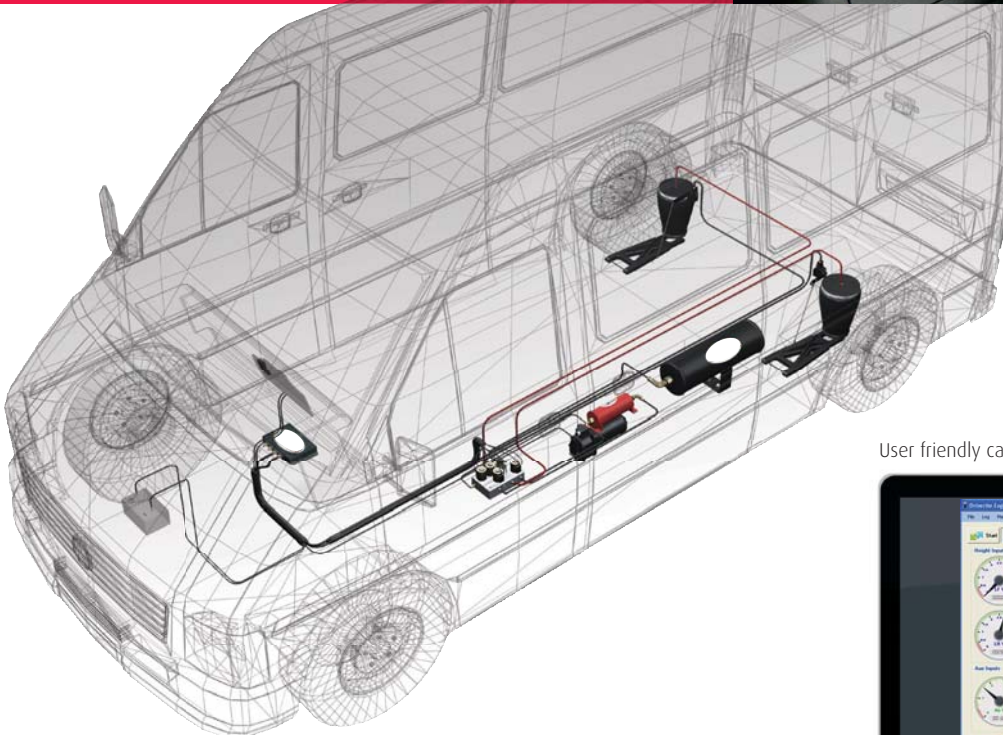

User friendly calibration and diagnostic tools





Tailor Made Solutions

Drive-Rite serve a broad range of businesses and industries and our ability to provide a quick turnaround for special projects and applications (large and small) has been a feature much appreciated by the Specialist Vehicle Convertors. Having worked for many years in the aftermarket industry Drive-Rite have gained invaluable knowledge of the customers real needs and have delivered

on supplying reliable and cost effective solutions resulting in ultimate customer satisfaction. Drive-Rite also delivers quality, safe and reliable suspension solutions at the highest level to the OEM market. Drive-Rite provide an unparalleled level of customer service and offer a unique partnership to all its customers large and small.





www.driveriteair.com

At Drive-Rite we are continually investing in and developing our online presence, to enhance our customers' experience and support.



Global Distribution



Algeria
Australia
Austria
Belarus
Belgium
Bosnia & Herzegovina
Brazil
Bulgaria
Canada
China
Croatia
Cyprus
Czech Republic
Denmark

Egypt
England, Scotland, Wales
Estonia
Finland
France
Georgia
Germany
Gibraltar
Greece
Greenland
Holland / Netherlands
Hungary
Iceland
India

Ireland
Israel
Italy
Japan
Jordan
Kazakhstan
Korea
Kuwait
Latvia
Lebanon
Liechtenstein
Lithuania
Luxembourg
Macedonia

Malaysia
Malta
Moldova
Monaco
Morocco
New Zealand
Norway
Poland
Portugal
Romania
Russia
Saudi Arabia
Singapore
Slovakia

Slovenia
South Africa
Spain
Sweden
Switzerland
Taiwan
Thailand
Tunisia
Turkey
UAE
Ukraine
United States
Yugoslavia

The Drive-Rite program is well supported by an ever growing, extensive, well trained and focused Distributor Network, which provides a full After-Sales program for the complete product range.



Drive-Rite Ltd

Unit 626 Kilshane Avenue
North West Business Park
Ballycoolin, Dublin 15
Ireland

Tel: + 353 1 861 2632

Fax: + 353 1 861 2647

info@driveriteair.com

DRIVE RITE
AIR SUSPENSION SYSTEMS